

Frontplattenausschnitt (Rückseite)
Panel cut out (rear side)

Print-Bohrplan (Bestückungsseite)
PCB-Layout (component side)

Detail X LED size: 0603 (max height: 0.8mm)
5:1 Recommended solder pad layout:

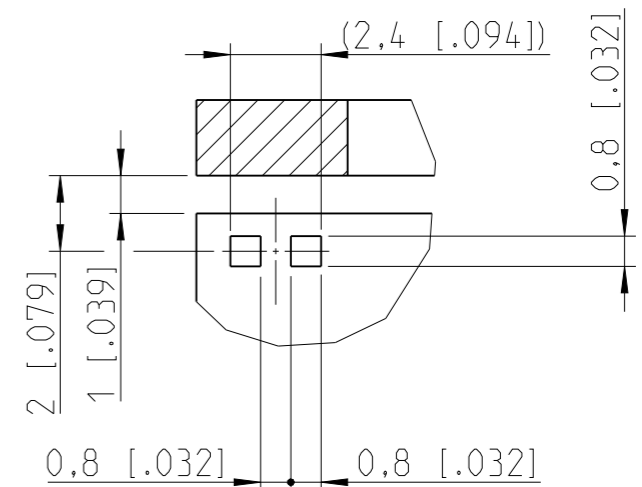
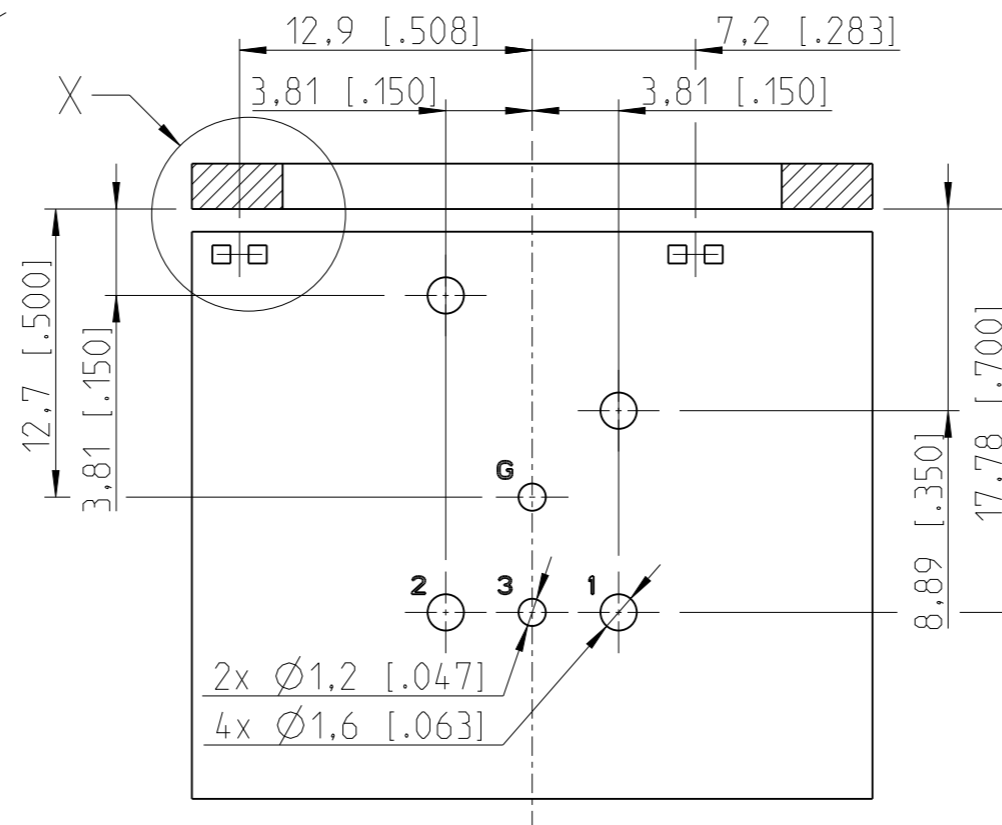
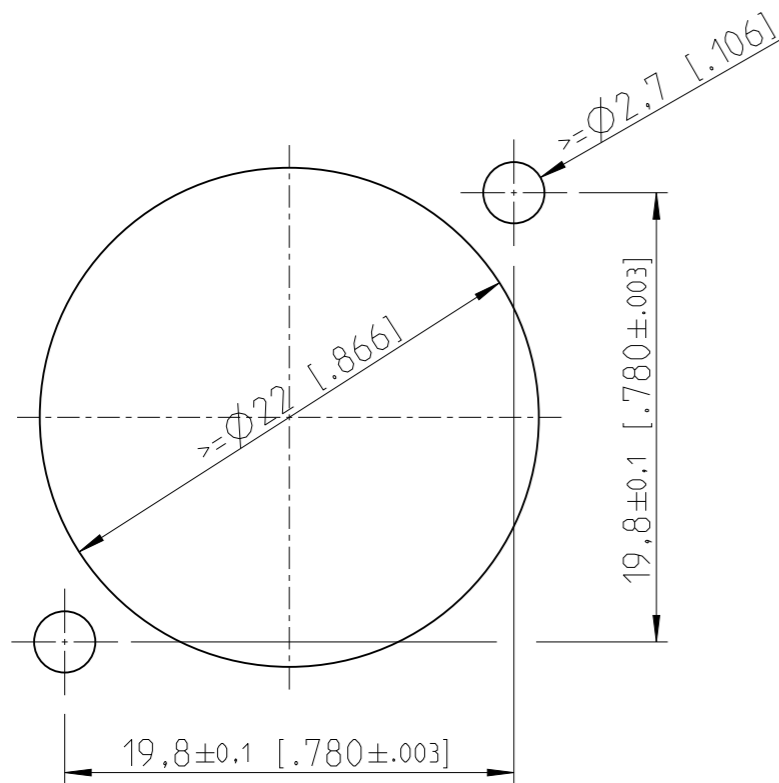

Sheet Number 1/1	Projection 1st Angle	Scale 3:1	Format A3	Tolerancing ISO 2768-mK	
ECN Number -			Created 25.10.2021	kez	
Description ST-NC3MAH-LR			Modified n.a.	n.a.	
			Approved		
			Status		
NEUTRIK		3D Model ID 30009279	Document ID 20003648	Revision -	