



# OPERATING & ASSEMBLY INSTRUCTION

## NAC3MX-W | powerCON TRUE1

### A. OPERATING INSTRUCTION

#### Application:

The powerCON TRUE1 system is certified as a connector with breaking capacity according IEC 60320, VDE 0625. It is intended for use as an appliance coupler and interconnection coupler. It serves to supply power to an appliance and from an appliance to other equipment. To be installed by qualified person only.

#### Connector Assignment:

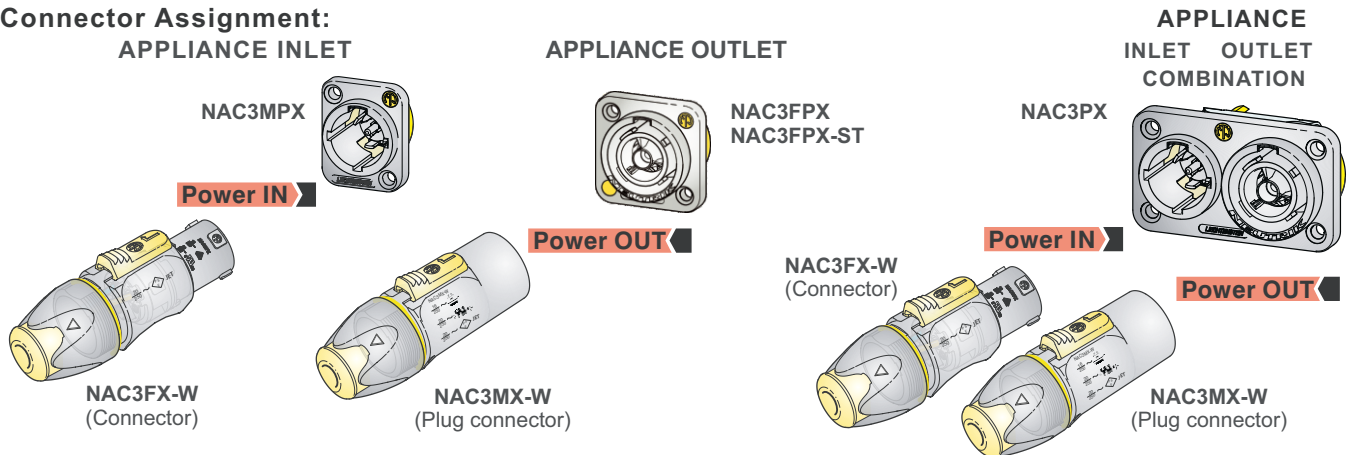

<b>Approval based:</b>	<b>VDE</b> EN 60320-1/EN60320-2-2	<input checked="" type="checkbox"/>	<b>UL</b> UL 498 / CSA C22.2 No. 182.3	<input checked="" type="checkbox"/>
<b>Rating:</b>	250 V ac / 16 A		250 V ac / 20 A	
<b>Cable Type:</b>	H05VV-F3G 1.0 mm <sup>2</sup> , Length max. 2 m H05VV-F3G 1.5 - 2.5 mm <sup>2</sup> H07RN-F3G 1.5 mm <sup>2</sup>		SJTOW, SJOOW 3 x 12 AWG	
<b>Strain Relief:</b>	White chuck		White chuck	
<b>Cable O.D.:</b>	6.0 - 12.0 mm		6.0 - 12.0 mm	

### B. ASSEMBLY INSTRUCTION

**A** Insert cable into the bushing and housing.

**Note:** "Apply cable pulling lubricant to cable jacket."

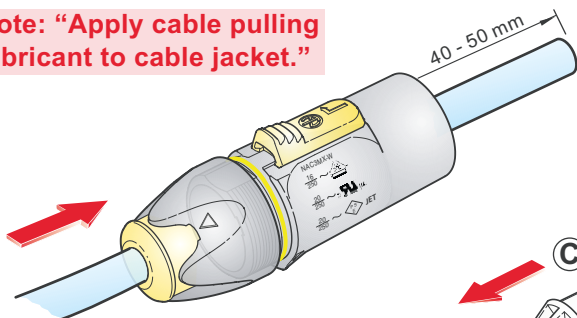

**B** Separate the housing from the bushing (cable remain in bushing)

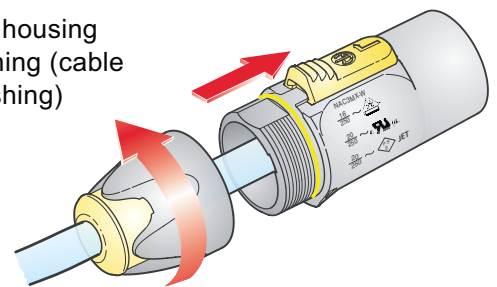

**C** Place the chuck over the cable.

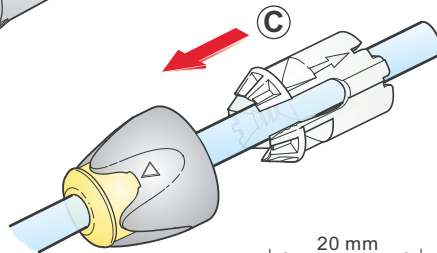

**D** Prepare the cable as shown.

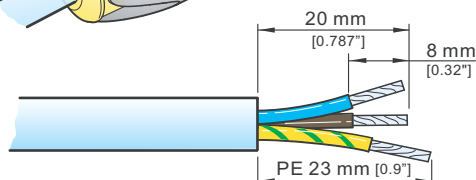

**VDE** (EN 60320-1/EN60320-2-2)

**i Recommendation:**  
Wire Pulling Lubricant - LUB-I/0.95 from 3M™

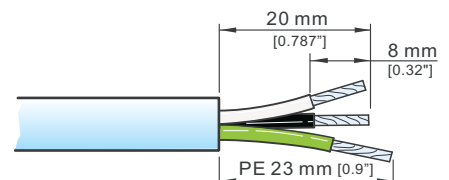

**UL** (UL 498 / CSA C22.2 No. 182.3)



**E**

Torx size T8  
Torque Value 0.7 Nm

Wiring	VDE	UL
L →	brown	black
N →	blue	white
⊥ →	green / yellow	green

**F**

**Important:** Align rubber key and latch.

**Important:** Push and turn simultaneously.

Slide the chuck onto the insert (1) and then both together into housing (2).  
**Important:** Align the chuck and insert by positioning the nose into the keyway.

**G**

Torque Value 2.0Nm  
PRESS FIRMLY

Wrench size 13 mm

Slide the bushing up the cable and tighten it with the tool as shown.  
**Important:** Yellow O-ring to hide to achieve IP protection (6).

(Tool available: Art. No. HTAC)

**FOR DISASSEMBLY - OPEN TWIST LOCK!**

- Press with screw driver to unlock
- Turn bushing 360°.
- Repeat step ①+② until bushing is unscrewed.

**CAUTION**

**FORCE**

To ensure protection category, do not expose the connection to bending forces (e.g. do not attach loads to the cable, no free-dangling cable windings etc.).

**SAFETY WARNING**

For safety and certification reasons the connector must be replaced in case of any broken parts or excessive wear and tear.

NEUTRIK AG	LI	T: +423 / 237 24 24	F: +423 / 232 53 93	NEUTRIK France	FR	T: +33 1 / 4131 6750	F: +33 1 / 4131 0511
NEUTRIK USA Inc.	USA	T: +1 704 / 972 3050	F: +1 704 / 438 9202	NEUTRIK Tokyo Ltd.	JP	T: +81 3 / 3663 4733	F: +81 3 / 3663 4796
NEUTRIK (UK) Ltd.	UK	T: +44 1983 / 811 441	F: +44 1983 / 811 439	NEUTRIK Hong Kong Ltd.	HK	T: +852 / 2687 6055	F: +852 / 2687 6052
NEUTRIK Vertriebs GmbH	DE/NL/AT/DK	T: +49 8131 / 280 890	F: +49 8131 / 280 830	NEUTRIK India Pvt. Ltd.	IND	T: +91 / 982 05 43 424	F: +91 / 22 26163 540