



ASSEMBLY INSTRUCTION

etherCON | CAT6A Chassis Connector

NE8FDX-Y6-W with rubber sealing - IP65

Tools:

- HX-CAT6A or Parallel Presstool
- Side cutter

Wire size: Solid: AWG 26/1 - AWG 22/1
 Stranded: AWG 26/7 - AWG 22/7
Insulation Diameter: > 0.85 - 1.60 mm

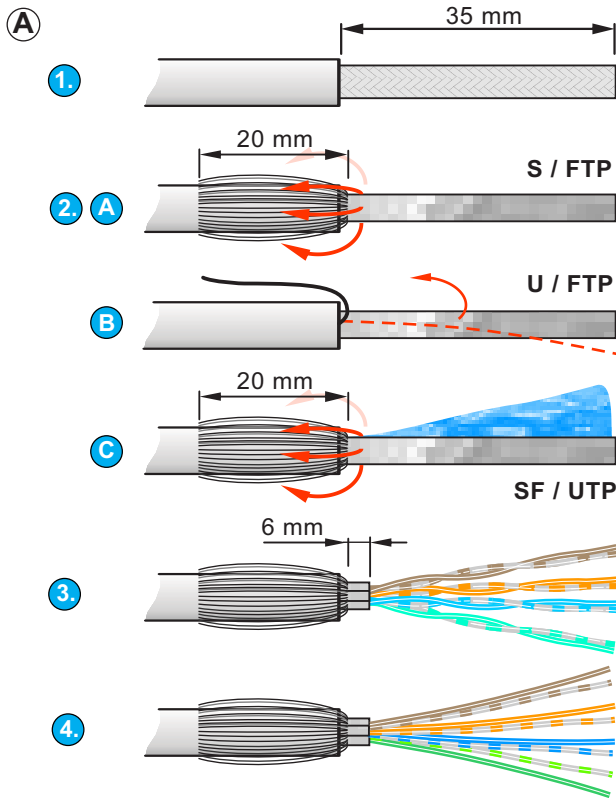

- (A)**
1. Prepare the cable as shown and strip the jacket at a length of 35 mm.
 2. **A. S / FTP**
Cut off braided shield to approx 20 mm and fold the shield backwards.
B. U / FTP
Remove the foil of the paired wires and bend back the drain wire for easier handling during assembly. Drain wire to be used for grounding.
 3. Remove the pair screening (if existing) to max. 6 mm.
 4. Presort, untwist and straighten the wires as shown. Unstraightened wires could potentially harm the IDC.

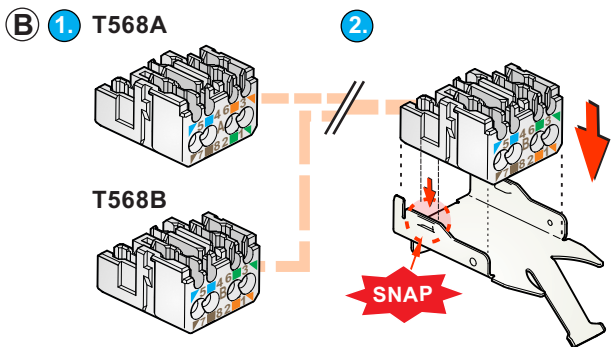

- (B)**
1. Delivery condition:
Wire management T568A & T568B disassembled.
 2. Depending on designated wiring standard, press either T568A or T568B – wire management into the grounding sheet metal until you hear a snap.

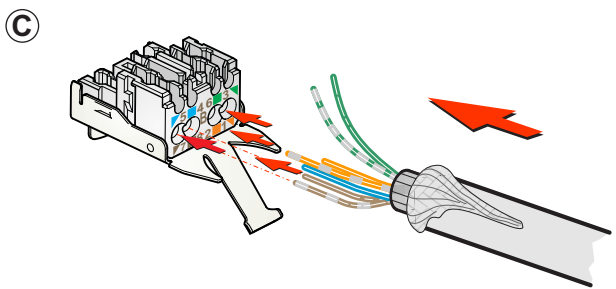

- (C)** Insert the wires into the designated position of the wire management as per below wiring scheme, either T568A or T568B.

Component side!	Connection		
	Color code		RJ 45 PIN No.
	T568A	T568B	
	W - G	W - O	1
	G	O	2
	W - O	W - G	3
	BL	BL	4
	W - BL	W - BL	5
	O	G	6
	W - BR	W - BR	7
	BR	BR	8

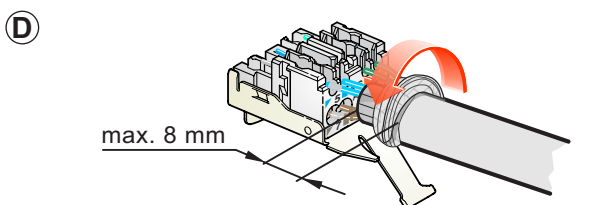

- (D)** Wrap the braided shield or drain wire around the cable jacket (max. 8 mm).

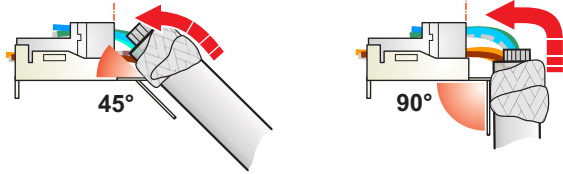
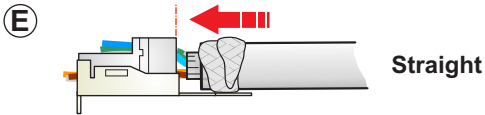

E Attention:
The distance between the cable jacket and the wire management shall be as short as possible.

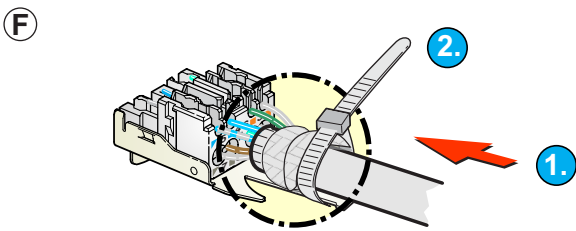

F Apply the cable tie for strain relief and after tightening cut off the excess length.

Attention:
Braided shield or drain wire must be covered by the cable tie.

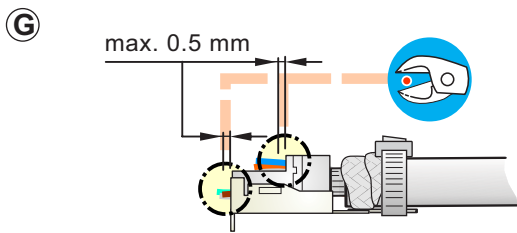

G Cut all wires with a wire cutter.
Allow wires to protrude max. 0.5 mm.

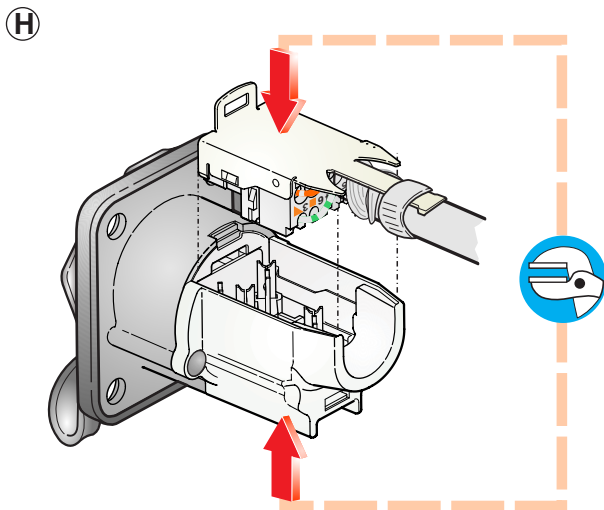

H Use the HX-CAT6A or a pliers wrench to press the wire management and housing together.

Open the connector

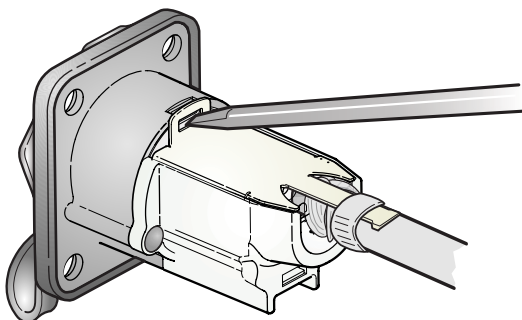

Open the wire management via the designated lug by help of a flat screwdriver.



ASSEMBLY

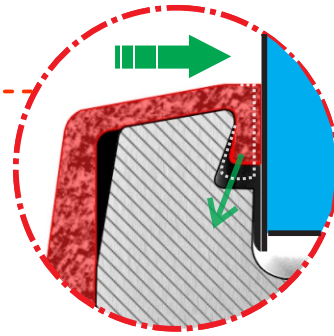
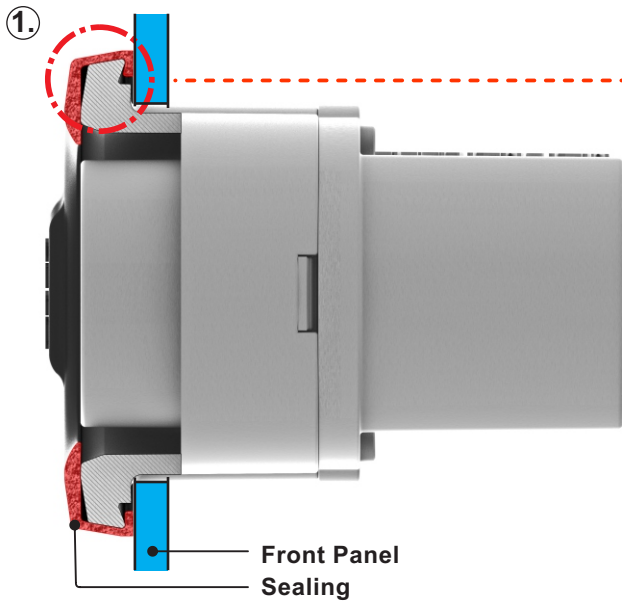

Flange shape ensures proper sealing.

ATTENTION:

- ① Sealing must be positioned well
- ② Position the supplied washers
- ③ Diameter of countersunk screw head min. 5.0 mm and max. 6.0 mm*
- ④ Maximum allowable torque 0.4 Nm

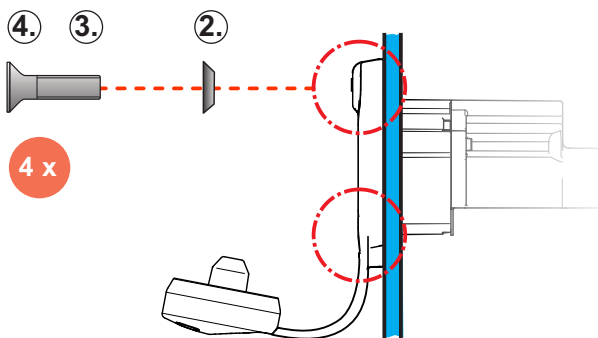

Panel Cutout (Rear Side)

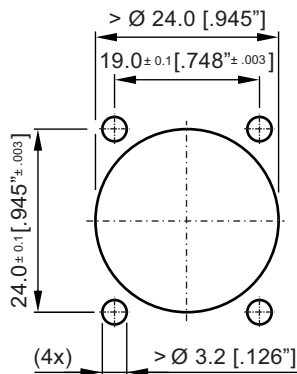

*Countersunk screw

